



DURAS® INFLATABLE BOAT

OWNER'S MANUAL

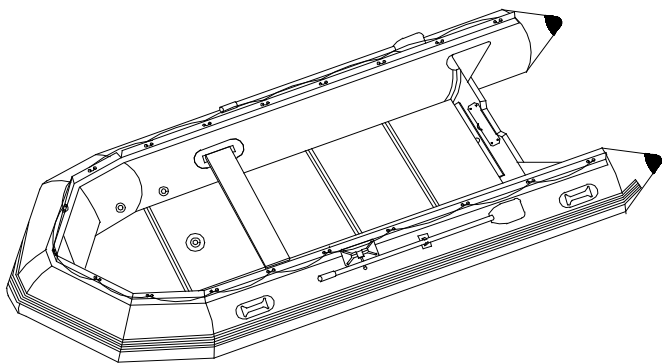

Table of Contents

About your new Duras[®] Inflatable Boat	Page 1
Assembly Instruction	Page 3
Motor Installation	Page 5
Capacities	Page 5
Troubleshooting	Page 6
Using your Duras[®] Inflatable Boat	Page 7
Some Other Points to Remember	Page 8

About your new Duras[®] Inflatable Boat

Thank you for purchasing a Duras Inflatable Boat. We hope you will get many years of use from your new boat. Your Duras Inflatable Boat has several unique features that make it a solid and reliable boat. For future reference, record your Duras purchase information below

Record Your Purchase Information Here	
Purchase Date :	
HIN (Serial #) :	
Purchased From :	

Below is a brief overview of the structure of the boat, standard equipment, and assembly instructions.

1. Standard Equipment for DX86, DX96 and DX104

* Boat hull with carrying bag	* High pressure foot pump
* Floorboards or Air Floor	* Aluminum bench seat
* Stringers (included on floorboard models)	* Owners manual
* Towing rope	* Pressure gauge
* 2 Oars	* Repair kit (includes valve removal tool)

2. The 1000 Denier Hull Material

The 1000 denier hull material is a rugged, solid material that operates with a 3.6 PSI working pressure.

3. The Air Compartments

All Duras Inflatable Boats have three air chambers in the tube and an inflatable keel. The air chambers are completely separate and ensure buoyancy in the event of a single chamber failure.

4. The One-Way Valve

Your Duras Inflatable Boat utilizes a one-way valve, a proven design that has been used for 20 years. This simple, rugged, one-way valve makes inflation easy. The inner valve design allows air to flow into the hull but not out and the outer valve cap makes the seal permanent. The plastic stem on the inner valve allows the boat to be deflated. Push in the inner valve and turn it to release air. Make sure the plastic stem is in the out position for inflation.

5. Rear Drain Valve

All Duras Inflatable Boats have a rear drain valve to drain water from the inside of the hull.

6. Foot Pump

All Duras Inflatable Boats come with a deluxe high pressure foot pump to ensure the boat is inflated to the recommended air pressure.

7. Pressure Gauge

All Duras Inflatable Boats come with a pressure gauge to ensure the boat is inflated to the recommended air pressure.

8. Repair Kit

All Duras Inflatable Boats come with a repair kit which includes glue, patch material and a valve removal tool.

Assembly Instruction

1. Unfold the Hull

Remove the hull from its box and take it out of the boat bag. Clear a flat space, making sure it is clean and free of sharp objects, and unfold your boat so it is laid out flat.

2. Inflate slightly

Inflate tube chambers to approximately 30%. Inflate side tubes first, then the bow tube. Install either floorboards or air floor.

NOTICE: Do not use an air compressor to inflate your boat. Damage to your boat caused by over inflation is not covered by your Limited Warranty.

3. Floorboard Assembly

- a. Place floorboard No. 1 at the bow part, then place floorboard No.4 at transom, then place floorboards No. 2 and No. 3 as shown in diagram.
 - Make sure that keel valve is located at the center of the hole in floorboard No.1.
- b. Press down on floorboard No. 2 and No. 3 at the same time so that the floorboards lay flat.

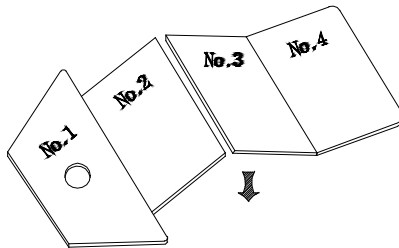

Do not assemble the floorboards with bare feet, and keep your fingers and toes out of the way to avoid getting pinched.

Stringers

Insert aluminum stringers into side edges of the floorboards making sure that the stringers overlap each board to ensure floorboards are straight and rigid.

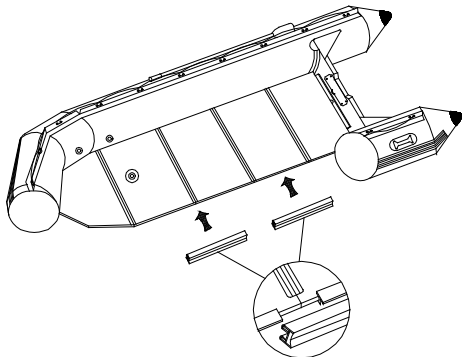

Air Floor Model :

- Insert aluminum floor brace/slat into the space provide on the bottom of the air floor (located towards the front of air floor). The brace ensures optimal hull shape is maintained at higher speeds.
- Put the air floor in boat and flatten. Pay special attention to insert the edge of the air floor between the floor and inside of the tube.
- Be sure that the air floor access hole to the keel's air valve is aligned properly.
- Inflate the air floor to a minimum of 6psi or maximum of 8psi.

4. Aluminum Seat

Inflate chambers to 90% of their recommended pressure and slide your aluminum seat onto the attachments located on the tubes.

5. Finish inflation

- Inflate side tubes first, then the bow tube to ensure equal pressure in all tubes.
- Inflate hull air chambers to 100%, or 3.6psi.
- Inflate keel. For optimal performance inflate keel to 80% of maximum capacity

6. Deflation

Remove the outer valve caps to expose the yellow plastic stem on the inner valve. Press the yellow plastic stem in to release air pressure, and turn it to lock the valve in the open position. Deflate each hull chamber 50-75% before completely deflating any of the air chambers.

NOTICE: Do not deflate one chamber fully while others are fully inflated. Improper deflation could damage the bulkheads of your boat.

Remove the floorboards by first removing the aluminum side stringers.

Motor Installation

The maximum rated horsepower for Duras Inflatable Boats is as follows:

MODEL	MAX (hp)
DX86	8 hp
DX96	10 hp
DX104	15 hp



If you install a motor larger than the maximum rated horsepower for your boat, you could have control problems and risk serious injury. Never exceed the maximum rated horsepower.

Read the instruction manual supplied by the outboard motor manufacturer. Outboard motor specifications vary and some require special installation procedures. Below is a general outline:

- Set the motor in the full upright tilt position.
- Place the motor in the center of the transom.
- Screw the mounting brackets securely to the transom.

Capacities

The maximum capacities for Duras Inflatable Boats are as follows:

MODEL	MAX. CAPACITY
DX86	950 lbs/430 kgs or 3 persons
DX96	1050 lbs/475 kgs or 4 persons
DX104	1190 lbs/540 kgs or 4 persons



If you exceed the maximum capacities for your boat, you could have control problems, capsize or swamp and risk serious injury. Never exceed the maximum capacity.

Troubleshooting

1. Leaks

If you are losing air pressure (unrelated to cold weather), check the boat for leaks, starting with the valves. The best tool to find leaks is soapy water in a spray bottle. Spray soapy water around the valve. If you see bubbles forming, check your valve seating and base and be sure the valve insert is screwed tight using the valve removal tool located in the repair kit. If you continue to have problems, it may be necessary to replace the valve.

2. Finding Punctures

If the boat is losing air, and all the valves are not leaking, you may have a small puncture. Small punctures can be repaired easily. Spray soapy water around the inside and outside of the hull until air bubbles reveal the position of the leak.

3. Rips or Tears

Your Duras Inflatable Boat comes with a repair kit as standard equipment. If you no longer have your repair kit, you can order a new one from your dealer. Cut a patch of repair material large enough to overlap the damaged area by approximately 1/2", and round off the edges. The repair area must be roughed up using sandpaper or other abrasive material for glue to properly adhere to the area. Apply glue to the under side of the repair patch and around the area to be repaired. Too much glue will interfere with a proper repair. Allow adhesive to become tacky for 2-4 minutes, and then place the repair patch on the damaged area. Use a weight to apply 3-5 lbs. of pressure for 12 hours. After the repair patch has dried, apply glue around the edges for a complete seal (dry 4 hours).

4. Large and Difficult Repairs

If you have a difficult repair, contact your local dealer for advice on the best way to fix your boat.

Using Your Duras® Inflatable Boat

1. Rowing

Duras Inflatable Boats are equipped with oars and oar locks as standard equipment. The oars can be attached to swiveling oarlocks which allow for easy rowing.

2. Motoring & Safety

All boats have their own unique handling characteristics, so take time to familiarize yourself with how your boat maneuvers in various conditions. Basic seamanship is beyond the scope of this owner's manual, but we would like to go over a few fundamentals.

- It is your responsibility to be aware of and comply with all relevant safety regulations.
- In all water sports, you should have reasonable swimming ability.
- Always respect the sea and the weather, as both can change rapidly and have surprised even the most seasoned mariners.
- Always carry enough Personal Flotation Devices.
- Always use U.S. Coast Guard or C.E. approved life jackets, as this is your assurance that the life jackets can provide sufficient buoyancy in the water.
- We strongly suggest that all boaters enroll in one of the excellent water safety courses offered by the Power Squadron or Coast Guard Auxiliary.

Some Other Points to Remember

- After 2 or 3 days, there may be a small decrease of pressure due to temperature change.
- Before undertaking a long trip, inflate the boat for a full 24 hours to be sure all chambers are completely airtight.
- Do not allow children to drive the boat unsupervised by adults.
- Avoid sharp objects when coming to dock or shore.
- Always bring your oars along, installed in place.
- If you see water coming into the boat, check the following:
 - ① Is the drain valve open?
 - ② Is the diaphragm in the drain valve working properly?
 - ③ Has it rained recently?
 - ④ Is there a hole in the floor?

Cleaning & Storage:

- ① Wash off sand and dirt and let completely dry before storage.
- ② Do not use harsh chemical cleaners or cleaners containing abrasives. Cleaners containing silicone are not recommended as these may adversely affect the hull material.
- ③ Do not store in extreme temperatures (*i.e.*, over 150F/below - 10F).
- ④ Store in a clean and dry place.

Dealer Information :

Copyright © 2012 Tohatsu America Corporation. All rights reserved. No part of this manual may be reproduced or transmitted in any form or by any means without the express written permission of Tohatsu America Corp.

Duras® Inflatable Boats, distributed by Tohatsu America Corporation, Farmers Branch, Texas

DZOM001-A 201201